

1N4448

FAST SWITCHING SURFACE MOUNT DIODES

DO-35(GLASS)

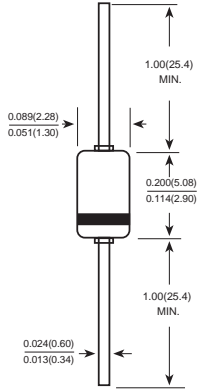

Dimensions in inches and (millimeters)

FEATURES

- ◆ Fast switching Speed.
- ◆ Surface Mount Package Ideally Suited For Automatic Insertion.
- ◆ Silicon Epitaxial Planar Construction.
- ◆ Lead free in compliance with EU RoHS 2011/65/EU directive

MECHANICAL DATA

Case: Molded Glass DO-35

Terminals: Plated axial leads, solderable per MIL-STD-750, Method 2026

Polarity: Color band denotes cathode end

Mounting Position: Any

Weight: 0.005 ounce, 0.13 grams

MAXIMUM RATINGS AND ELECTRICAL CHARACTERISTICS

PARAMETER	SYMBOL	VALUE	UNITS
Peak Reverse Voltage	V_{RM}	100	V
Maximum DC Blocking Voltage	V_{DC}	75	V
Maximum Average Forward Current at $T_A=25^{\circ}C$ And $f \geq 50Hz$	I_{AV}	150	mA
Surge Forward Current at $t < 1s$ and $T_J=25^{\circ}C$	I_{FSM}	500	mA
Power Dissipation at $T_A= 25^{\circ}C$	P_{TOT}	500	mW
Maximum Forward Voltage at $I_F=100mA$	V_F	1	V
Maximum Leakage Current at $V_R=20V$ at $V_R=20V, T_J= 150^{\circ}C$	I_R	25 50	nA μA
Maximum Capacitance at $V_F=V_R=0$	C_J	4	pF
Maximum Reverse Recovery Time From $I_F = -I_R = 10mA$ to $I_{RR}=-1mA, V_R=6V, R_L=100 \Omega$	t_{rr}	4	ns
Typical Maximum Thermal Resistance	$R_{\theta JA}$	350	$^{\circ}C / W$
Junction Temperature and Storage Temperature Range	T_J, T_S	-65 to +175	$^{\circ}C$

NOTE:

1. C_J at $V_R=0, f=1MHz$

2. From $I_F=10mA$ to $I_R=1mA, V_R=6Volts, R_L=100\Omega$

RATINGS AND CHARACTERISTIC CURVES 1N4448

FORWARD VOLTAGE

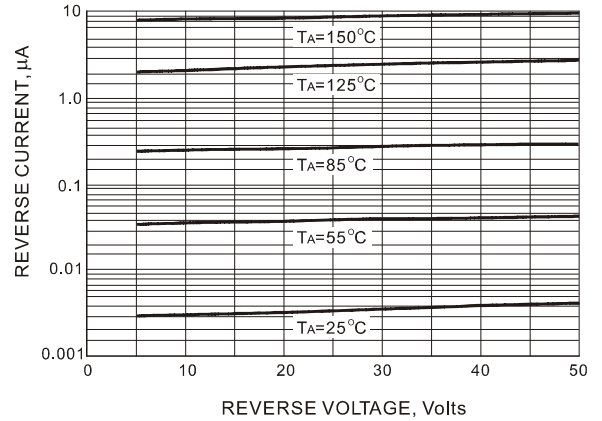
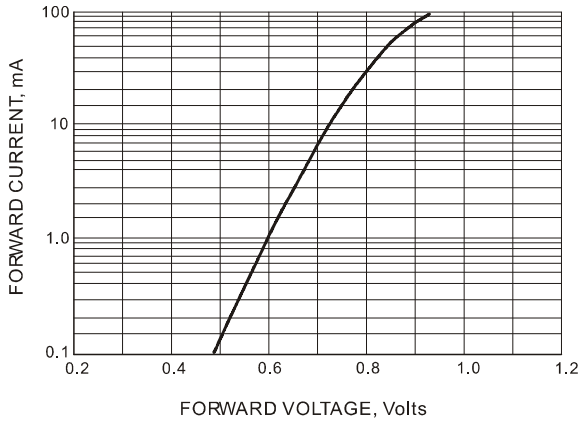

LEAKAGE CURRENT

TYPICAL CAPACITANCE

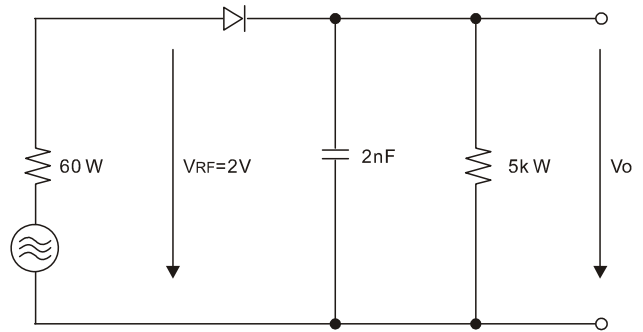
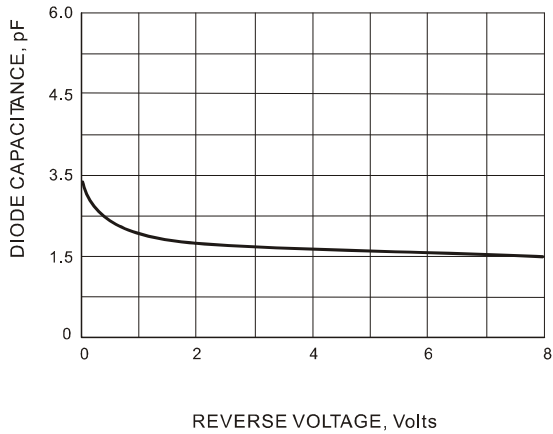

RECTIFICATION EFFICIENCY MEASUREMENT CIRCUIT